

Class II construction

Please read carefully: This product should be installed by a licensed electrician or similarly qualified person. Read through these instructions completely before commencing installation. Retain for future use.

1 Specifications

Cat. No.	LBL014KWE, LBL014KBL
Supply Voltage	230 - 240 V a.c. 50 Hz
Input Power	16 W
Lumens Output	1530 lm
Efficacy	96 lm/W
Colour Temperature	Cool White - 4000 K (Nominal)
Power Factor	0.55
Colour rendering index (CRI)	80+
Beam Angle	118°
Lifespan	36,000 hrs (@25°C ambient free air) 25,000 hrs (@40°C ambient)
Dimmable	No
IP Rating	IP65
Size	Ø 300 x 100 mm

2 Installation

Isolate 240 V mains before opening fitting for maintenance or installation. (Please refer to figure below)

- Step 1: Remove the diffuser from the fitting by removing the 3 x rubber lugs and loosening the 3 x screws as shown in Fig.1.
- Step 2: Use the fitting as a template to mark the screw positions onto the wall/ceiling. Drill and fix the mounting lugs in the wall as shown.
- Step 3: Connect the connecting lead (tails) to mains power then install the fitting onto the wall/ceiling using 3 x screws as shown in Fig. 2.
- Step 4: Install the diffuser onto the base, tighten the 3 x screws provided, and torque to 0.4 Nm max. Do not overtighten. Locate and push the rubber lugs into the slots as shown in Fig.2.

DO NOT MEGGER TEST.

2 Installation (cont.)

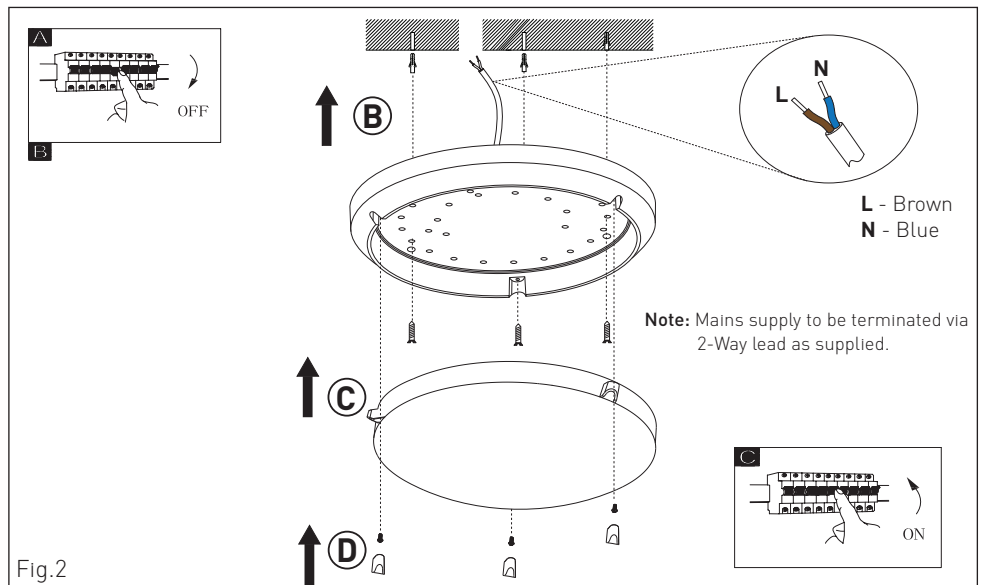
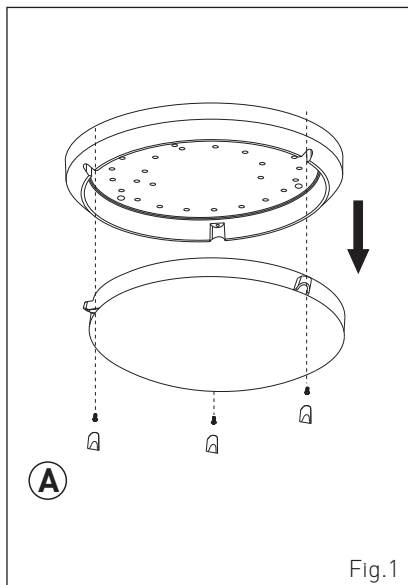

3 Maintenance / Cleaning

1. This product should only be cleaned with a damp cloth. Cleaning agents and solvents should not be used.
2. This product should not be cleaned with a hose.

Product Notes

1. This product must be installed and used as per these instructions. **2.** An IP rating of IP65 is completely protected against dust and generally considered suitable for fully exposed external installations, but not for high-pressure hoses. **3.** The IP rating of this product is only valid when installed on a flat and non-porous surface. Additional sealing may be required for irregular surfaces. **4.** The mounting screws on this product should be tightened to a maximum torque of 0.8Nm. Over tightening may damage the product. **5.** This product contains no serviceable parts and no attempt should be made to repair it. If the product is faulty it should be discarded. **6.** This product is not suitable for installation in hazardous and/or corrosive areas. This product is not suitable for marine environments such as areas subject to salt spray and/or mist. **7.** Electrical installations periodically receive transient over-voltages. This product has been designed to minimise the effect of such voltages on the connected equipment. It may not give full protection for extreme over-voltage transients such as those resulting from a close lightning strike. **8.** This product has been designed to operate in ambient temperatures -5°C to 40°C. **9.** The material in this product may vary in colour from batch to batch. Colour matching from one batch to another cannot be guaranteed. **10.** Extended exposure to UV rays (such as exposure to direct sunlight) may cause discolouration of this product. **11.** Stated lifespan is an average. The actual lifespan will vary according to individual circumstances. **12.** Legrand reserves the right to modify the specification of this product at any time. **13.** This product utilises intellectual property in the form of registered designs, trademarks, and/or patents. Such intellectual property remains the property of Legrand in all cases.

Warranty

Legrand Australia Pty Ltd warrants this product for a period of 5 years from the date of purchase.

These goods come with guarantees that cannot be excluded under the Australian and New Zealand Consumer Laws. You are entitled to a replacement or a refund for a major failure and compensation for any other reasonably foreseeable loss or damage. You are also entitled to have the goods repaired if the goods fail to be acceptable quality and the failure does not amount to a major failure.

See the Warranty card enclosed with this product for further details.

Customer Service

For all Customer Service and Technical Support please call Monday to Friday during business hours.

Legrand Australia
1300 369 777
www.hpm.com.au

Legrand New Zealand
0800 476 009
www.hpm.co.nz

ABN: 31 000 102 661

